

C11

User Manual



C11

User Manual

Document ID: 2CMC486001M0201

Revision: A

2010-12-13

Disclaimer

The information in this document is subject to change without notice and should not be construed as a commitment by ABB AB. ABB AB assumes no responsibility for any errors that may appear in this document.

In no event shall ABB AB be liable for direct, indirect, special, incidental or consequential damages of any nature or kind arising from the use of this document, nor shall ABB AB be liable for incidental or consequential damages arising from use of any software or hardware described in this document.

Copyrights

This document and parts thereof must not be reproduced or copied without written permission from ABB AB, and the contents thereof must not be imparted to a third party nor used for any unauthorized purpose.

The software or hardware described in this document is furnished under a license and may be used, copied, or disclosed only in accordance with the terms of such license.

© Copyright 2010 ABB AB. All rights reserved.

Trademarks

ABB AB is a registered trademark of the ABB Group. All other brand or product names mentioned in this document may be trademarks or registered trademarks of their respective holders.

Contact

ABB AB
P.O. BOX 1005
SE-611 29 NYKÖPING
SWEDEN
Tel: +46 155 295000
Fax: +46 155 288110

Table of Content

1 About this Manual	3
2 Product Overview	5
3 Installation	9
3.3.1 Wiring Diagrams	13
3.3.1.1 Outputs/inputs	13
4 User Interface	15
5 Meter Settings	21
6 Technical Description	27
7 Technical data	33
8 Troubleshooting	37
9 Service & Maintenance	39

Chapter 1: About this Manual

Overview

This chapter describes the conventions used in this manual. It also contains explanations and definitions of terms and definitions that are used in the document.

In this chapter





The following topics are covered in this chapter:

- 1.1 Conventions Used in this Document 4

1.1 Conventions Used in this Document

Symbols

This document contains warning, caution, note and tip icons that point out safety related conditions and other important or useful information.

Symbol	Description
	The electrical warning icon indicates the presence of a hazard which could result in electrical shock.
	The caution icon indicates important information or a warning related to the concept discussed in the text. It might indicate the presence of a hazard which could result in corruption of software or damage to equipment or property.
	The note icon alerts the reader to important facts and conditions.
	The tip icon gives the reader useful information related to the concept discussed in the text.

Chapter 2: Product Overview

Overview

This chapter describes the parts of the meter. It also contains information about the meter type.

In this chapter

The following topics are covered in this chapter:

2.1 Meter Parts	6
2.2 Meter Type	7

2.1 Meter Parts

Illustration

The parts of the meter are shown in the illustration below:

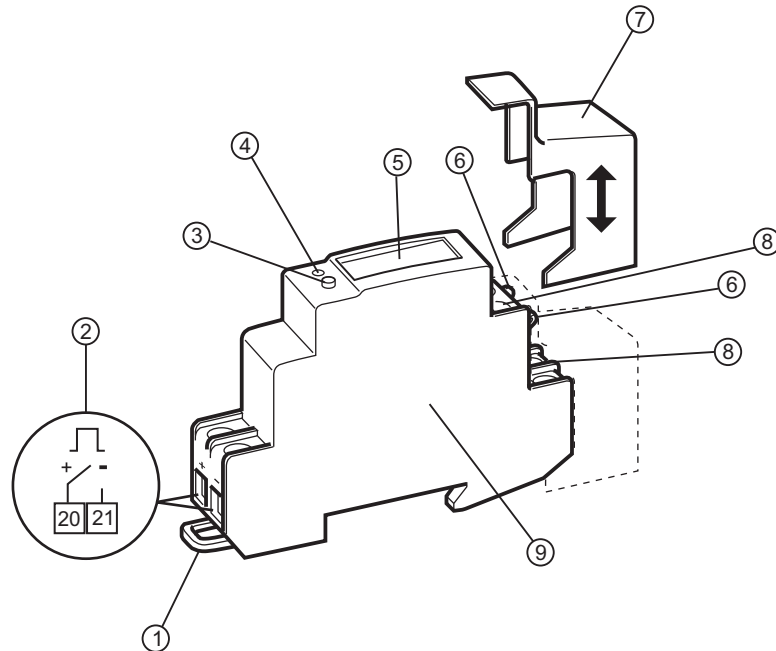

Parts description

The following table describes the parts of the meter:

Item	Description	Comments
1	DIN-lock	To fasten the meter on the DIN-rail.
2	Output	Terminal connections for the output.
3	Push button	For programming and reading metering data.
4	LED	Flashes in proportion to the energy consumed.
5	Display	LCD for meter reading
6	Sealing points	Seal thread can be used to seal the cover.
7	Sealable terminal cover	Sealable cover to protect the terminal blocks.
8	Terminal blocks	Terminal for all voltages and currents.
9	Product label	Contains information about the meter type.

2.2 Meter Type

C11 meter

The C11 is a compact meter for 1-phase metering. The meter is direct connected for currents up to max. 40 A.

Product label

The meter type information that is reflected on the product label is shown in the picture below:

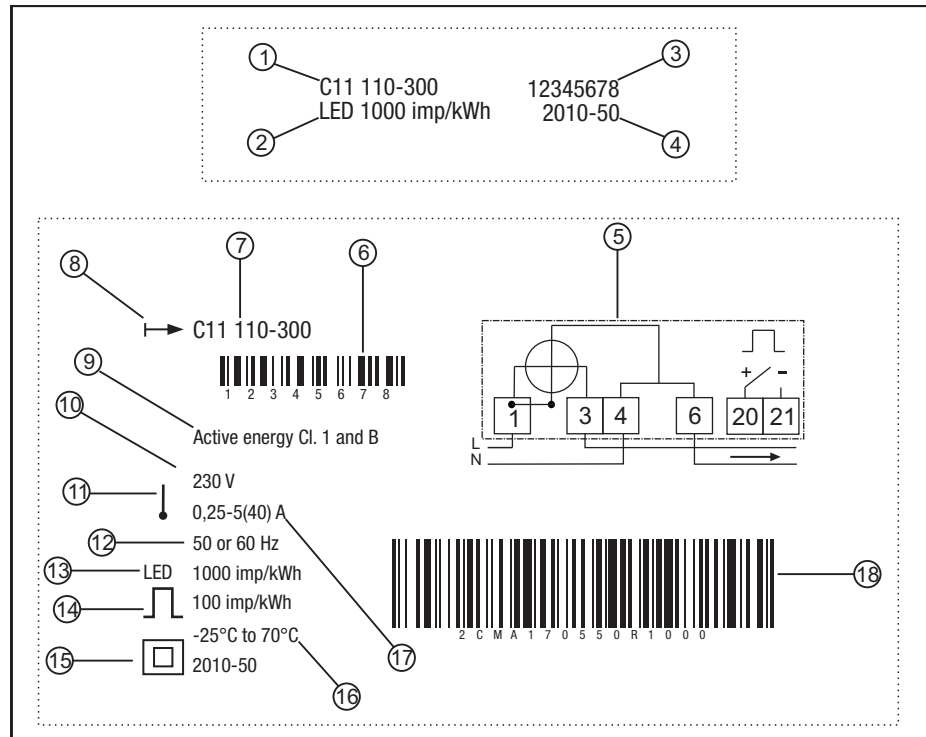

Label information

The information on the type label is explained in the table below:

Item	Description
1	Type designation
2	LED pulse frequency
3	Serial number
4	Manufacturing date (year and week)
5	Wiring diagram
6	Bar code with serial number
7	Type designation
8	Energy import
9	Accuracy (active energy)
10	Nominal voltage
11	One measuring unit

Product Overview

Item	Description
12	Frequency
13	LED pulse frequency
14	Pulse frequency
15	Protective class II
16	Operating temperature range
17	Rated current
18	ABB ID

Chapter 3: Installation

Overview

This chapter describes how to mount the C11 meter and how to connect it to an electricity network.

In this chapter

3.1 Mounting the Meter	10
3.2 Environmental Considerations	11
3.3 Installing the Meter	12
3.3.1 Wiring Diagrams	13

3.1 Mounting the Meter

General

This section describes different ways to mount the C11 meter. For some methods of mounting, additional accessories are needed. For further information about accessories, refer to Main Catalog (2CMC481001C0201).

DIN-rail mounted

The C11 meters are intended to be mounted on a standard (DIN 50022) DIN-rail. If this method of mounting is used no extra accessories are needed and the meter is fastened on the rail by snapping the DIN-rail lock onto the rail.

Wall mounted

The recommended way to mount the meter on a wall is to mount a separate DIN-rail on the wall and then mount the meter on the rail.

Standard DIN-rail

The following picture shows a standard DIN-rail.

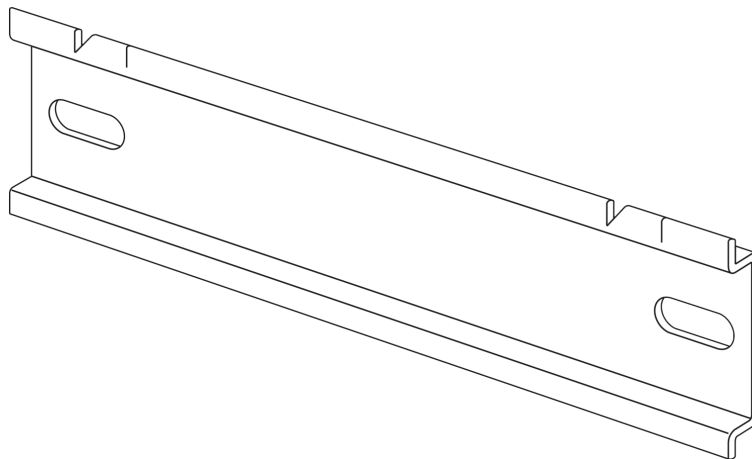

3.2 Environmental Considerations

Ingress protection

To comply with the protection requirements the product must be mounted in protection class **IP 51** enclosures, or better, according to **IEC60259**.

Mechanical environment

In accordance with the Measuring Directive (**2004/22/EC**), the product complies with **M1**, which means that it can be operated in "...locations with vibration and shocks of low significance, e.g. for instruments fastened to light supporting structures subject to negligible vibrations and shocks transmitted from local blasting or pile-driving activities, slamming doors, etc."

Electromagnetic environment

In accordance with the Measuring Directive (**2004/22/EC**), the product complies with **E2**, which means that it can be operated "...in locations with electro magnetic disturbances corresponding to those likely to be found in other industrial buildings."

Climatic environment

In order to work properly the product should not be operated outside the specified temperature range of -40°C - $+70^{\circ}\text{C}$.

In order to work properly the product should not be exposed to humidity exceeding the specified 75% yearly average, 95% on 30 days/year.

3.3 Installing the Meter



Warning – Electrical equipment should only be installed, accessed, serviced and maintained by qualified electrical personnel.

Working with high voltage is potentially lethal. Persons subjected to high voltage may suffer cardiac arrest, burn injuries, or other severe injuries. To avoid such injuries, make sure to disconnect the power supply before you start the installation.



Warning – For safety reasons it is recommended that the equipment is installed in a way that makes it impossible to reach or touch the terminal blocks by accident.

The best way to make a safe installation is to install the unit in an enclosure. Further, access to the equipment should be limited through use of lock and key, controlled by qualified electrical personnel.



Warning – The meters must always be protected by fuses on the incoming side.

In order to allow for maintenance of transformer rated meters, it is recommended that there should be a short circuiting device installed near the meter.

Installation requirements

To comply with the protection requirements the meter must be mounted in protection class IP 51 enclosures, or better, according to IEC 60259.

Meters with wireless communication should not be installed closer than 20 cm from people.

Install the meter

Follow the steps in the table below to install the meter:

Step	Action
1	Switch off the mains power.
2	Place the meter on the DIN-rail and make sure it snaps onto it.
3	Strip the cable insulation to the length that is indicated on the meter.
4	Connect the cables according to the wiring diagram that is printed on the meter and tighten the screws (0,8 Nm).
5	Install the circuit protection (max 40 A).
6	Connect the output to an external power supply (max 5-40 V). See the wiring diagram printed on the meter.
7	Turn on the mains power.

Verify the installation

The C11 meter has a red LED next to the push button on the front of the meter that flashes proportionally to the active energy. The LED has a fixed pulse frequency of 1000 imp/kWh and can be used to test and verify the installation. If the LED flashes when the mains power is turned on, the installation was successful.

3.3.1 Wiring Diagrams

2-wire connection

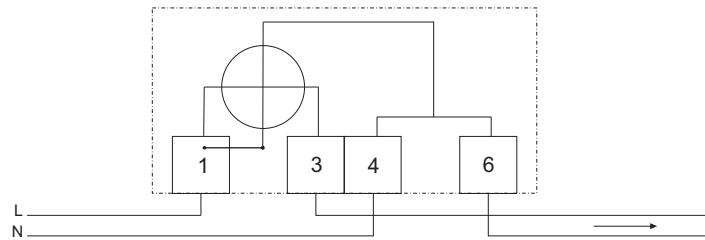

3.3.1.1 Outputs/inputs

Fixed, 1 output

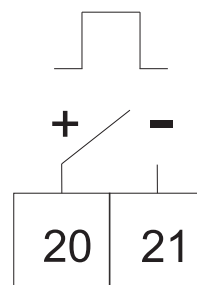

Chapter 4: User Interface

Overview

This chapter gives an overview of the display and of the functions of the button on the meter.

In this chapter

The following topics are covered in this chapter:

- 4.1 Display and buttons 18
- 4.2 Menu Structure 19

4.1 Display and buttons



Display

The display consists of both icons, digits and letters. The measured value/menu options are displayed with large letters vertically on the display, as well as horizontally on the lower part of the display. The measured unit is displayed vertically on the right side of the display, and the status icons are displayed at the upper part of the display, see figure below.



Status Icons

The status icons are shown in the table below.

Icon	Indication	Comment
	Active error	When a error has been detected, the icon will be lit on the display. When no error has been detected, the icon will be turned off.
	Metering in progress.	When a load is connected to the meter, the icon will flash to indicate metering. When no load is connected, the icon will be turned off.

Button

The meter has one push button which is located below the display. A short press on the button (less than 1 sec) will step through the menu/submenu. A long press (more than 1 sec) followed by a release of the button will open the set menu or select an item in the menu.

4.2 Menu Structure

Overview

This section will give an introduction to the menu structure.

Menu structure

The menu structure of the meter can be viewed in the following figure

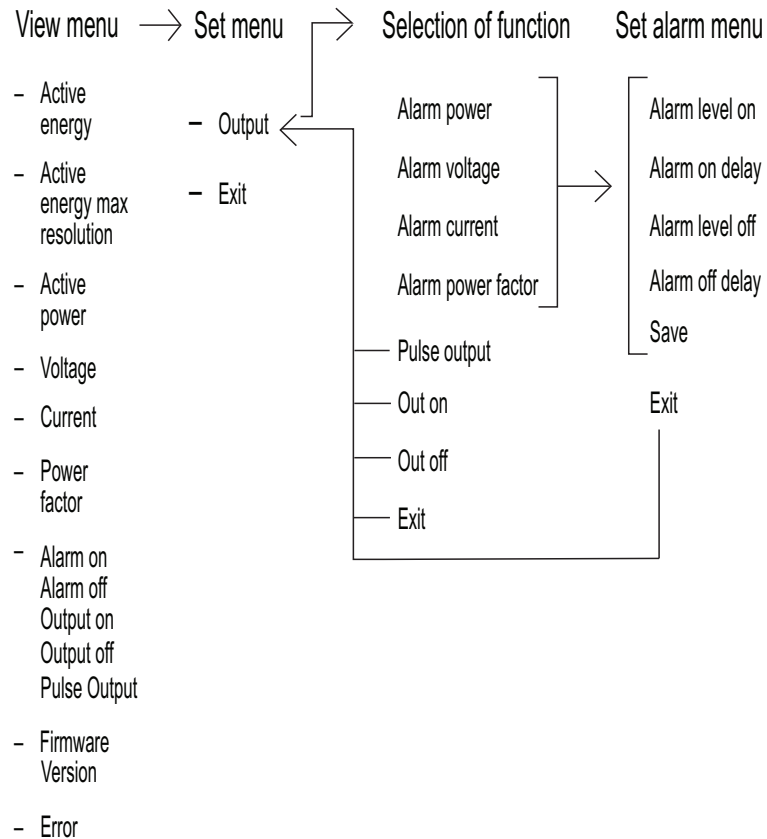

Navigation

To navigate in the menu, use the short press to navigate between the different menu items, and the long press to select a menu item. When performing settings, the short press is used to change the value of a specific setting, and the long press is used to toggle between different digits.

View menu

In the view menu, the following choices can be made.

Choice in menu	Output on display	No. of digits	No. of decimals	Unit	Min. value	Max. value
Active energy	<numerical value> kVh	6	0	kWh	0	999999
Active energy max resolution	<numerical value> Vh	6	3	Wh	0	999.999

Choice in menu	Output on display	No. of digits	No. of decimals	Unit	Min. value	Max. value
Active Power	<numerical value> VV	4	0	W	0	9999
Voltage	<numerical value> V	4	1	V	0	999.9
Current	<numerical value> A	3	1	A	0	99.9
Power factor	<numerical value>	4	3	N/A	0	1.000
Output state						
- Alarm on, or	AL On	N/A	N/A	N/A	N/A	N/A
- Alarm off, or	AL OFF	N/A	N/A	N/A	N/A	N/A
- Output on, or	OUt On	N/A	N/A	N/A	N/A	N/A
- Output off, or	OUt OFF	N/A	N/A	N/A	N/A	N/A
- Pulse out	PUL OUt	N/A	N/A	N/A	N/A	N/A
Firmware version	FC <numerical value>	4	N/A	N/A	FC 01	FC9999
CRC Part 1	C<hex value>	4	N/A	N/A	0000	FFFF
CRC Part 2	C<hex value>	4	N/A	N/A	0000	FFFF
Error	Er <numerical value>	4	N/A	N/A	N/A	N/A

Set menu

The set menu is used to set different options in the meter. The set menu is reached by using the long press when located in the view menu. The following choices are available in the set menu, see table below.

Choice in menu	Output on display
Output	SEt OUt
Exit	EXit

Set alarm menu

When choosing Exit, the menu will return to the view menu. When choosing Output, the following choices will be available.

Choice in menu	Output on display	Explanation
Alarm power	AL P VV	By choosing this option, the alarm will be set regarding to the measured power.
Alarm voltage	AL VOL V	By choosing this option, the alarm will be set regarding to the measured voltage.

Choice in menu	Output on display	Explanation
Alarm current	AL CUR A	By choosing this option, the alarm will be set regarding to the measured current.
Alarm power factor	AL PF	By choosing this option, the alarm will be set regarding to the measured power factor.
Pulse output	PUL OUT	By choosing this option, the pulse output function will be activated.
Out on	OUt On	By choosing this option, the output will be set to static on.
Out off	OUt OFF	By choosing this option, the output will be set to static off.
Exit	Exit	Go back to the set menu.

When either Alarm power, Alarm voltage, Alarm current or Alarm factor has been chosen, the following choices will be available.

Choice	Output on display	Unit	Explanation
Alarm level on	AL On	W/V/A/-	When the measured value passes the set value, the alarm will be triggered.
Alarm on delay	dEL On	seconds	When the measured value passes the set value and remains for the set time, the alarm will be triggered.
Alarm level off	AL OFF	W/V/A/-	When the measured value passes the set value, the alarm will be cleared.
Alarm off delay	dEL OFF	seconds	When the measured value passes the set value and remains for the set time, the alarm will be cleared.
Save	SAuE	N/A	This option saves the alarm settings.
Exit	EXit	N/A	Go back to the set menu without saving. Use this option to view the current alarm settings.

Chapter 5: Meter Settings

Overview

This chapter describes how to configure the functions of the meter, including alarm settings.

In this chapter

The following topics are covered in this chapter:

5.1 Setting the Output	22
5.2 Setting the Alarm	24

5.1 Setting the Output

About the output

The C11 meter has one output which can be used for three different purposes. When one of the three options has been chosen for the output, the remaining two options are automatically disabled.

- Alarm monitoring
The output is used for monitoring if an alarm has been triggered or not.
- Static level
The output is set as static, either as static on or static off.
- Pulse output
The output is set as a pulse output.

Output state

The Output state in the main menu indicates what function is activated. See table below for the different functions that can be activated

Activated function	Output on display	Comment
Alarm on	AL On	The alarm is set and has been triggered. The pulse output exit is deactivated.
Alarm off	AL OFF	The alarm is set but has not been triggered. The pulse output exit is deactivated.
Output on	OUT 1	There is always a continuous signal on the output.
Output off	OUT 0	The output is closed for all traffic, both inbound and outbound.
Pulse out	PUL OUT	The output is activated with a frequency based on measured energy. The alarm function is deactivated.

Set output to pulse output

To set the pulse output to be available for pulse measuring, perform the following steps when located in the view menu.

Step	Action	Comment
1	When located in the view menu, use the long press to get to the set menu.	-
2	Use the long press to get to the selection of functions menu.	-
3	Toggle through the menu to get to the Pulse out choice. Use the long press to choose Pulse out (PUL Out on the display).	The Pulse out choice in the selection of function menu is displayed as: PUL Out

Disable output

The output can also be disabled by performing the following steps when located in the view menu.

Step	Action	Comment
1	When located in the view menu, use the long press to get to the set menu	-
2	Use the long press to get to the selection of function menu.	-
3	Toggle through the menu to get to the Output off choice (OUt OFF on the display). Use the long press to choose the Output off.	The Output off choice in the view menu is displayed as: OUt OFF

Activate output

To activate the output, perform the following steps when located in the view menu.

Step	Action	Comment
1	When located in the view menu, use the long press to get to the set menu.	-
2	Use the long press to get to the selection of function menu.	-
3	Toggle through the menu to get to the Output on choice (OUt On on the display). Use the long press to choose Output on.	The Output on choice in the view menu is displayed as: OUt On

5.2 Setting the Alarm

About the alarm

The alarm function gives the user the possibility to set an alarm that will trigger when a defined limit is reached by the measured value. See table for more information.

Choice in menu	Unit	Output on display	Range
Alarm power	W	AL P VV	0-9999 W
Alarm voltage	V	AL VOL V	0-299.0 V
Alarm current	A	AL CUR A	0-40.00 A
Alarm power factor	-	AL PF C	0-1.000

If the value is set above the max range, the meter will automatically set the value to the max value allowed by the range.

Example: Alarm current is set to 100.0 A by the user, but the max value is 40.0 A, so the meter will use the max value, in this case 40.0 A.

If an alarm has been set, the output state will indicate if the alarm is triggered (AL On) or not (AL OFF). The magnitude of the set alarm is also displayed in the output state.

Set alarm

To set an alarm, perform the following steps when located in the view menu.

Step	Action	Comment
1	Use the long press to get to the set menu	-
2	Use the long press to get to the selection of function menu	-
3	Toggle through the menu to choose what magnitude to set. Choose one of the following: Alarm power (W), Alarm voltage (V), Alarm current (A) and Alarm factor (no magnitude).	Use the long press to choose.
4	Set the alarm value that the measured value must pass in order for the alarm to trigger (Alarm level on).	Use the short press to change the value of the digit, and the long press to step through the different digits.
5	Set the time frame that the measured value must pass the set alarm value in order for the alarm to trigger (Alarm on delay).	Use the short press to change the value of the digit, and the long press to step through the different digits.
6	Set the alarm value that the measured value must pass in order for the alarm to be cleared (Alarm level off).	Use the short press to change the value of the digit, and the long press to step through the different digits.

Step	Action	Comment
7	Set the time frame that the measured value must pass the set alarm value in order for the alarm to be cleared (Alarm off delay).	Use the short press to change the value of the digit, and the long press to step through the different digits.
8	To save the alarm settings and enable the alarm function, use the long press when located in the save-menu (SAuEon the display). After performing this setting, the alarm is set.	If not choosing the option save, the settings will not be saved and the previously saved setting will be used instead. The alarm will not be activated.

Read alarm

The Output option in the View menu shows whether a programmed alarm has been triggered or not. A triggered alarm displays as AL On, and an alarm that has not been triggered displays as AL OFF.

Chapter 6: Technical Description

Overview

This chapter describes the technical functions of the C11 meter.

In this chapter

The following topics are covered in this chapter:

6.1 Energy Values	28
6.2 Instrumentation	29
6.3 Outputs	30
6.4 Alarm	31

6.1 Energy Values

General

The energy values are stored in energy registers. The different energy registers can be divided into:

- Registers containing active energy.

The energy values can be read directly on the display by using the button on the meter.

Presentation of register values

In direct connected meters the energy is usually displayed with a fixed unit and number of decimals (normally kWh, with no decimals).

In case the energy is displayed with fixed units and number of decimals the energy will “roll over” to zeros when the energy is incremented if all nines are displayed. The meter can however contain more digits internally, which can be read out via communication if the meter is equipped with a communication interface.

6.2 Instrumentation

Instrumentation functions

The following table shows the complete instrumentation functions of the C11 meter.

Instrumentation	C11
Active power, L	X
Voltage L - N	X
Current L	X
Power factor, Total	X

Accuracy

All instrumentation data accuracy is defined within the voltage range -20% - +15% of the stated nominal voltage and within the current range 5% of the base current to the maximum current.

6.3 Outputs

About outputs

The C11 meter has one output which can be used for three different purposes. When one of the three options has been chosen for the output, the remaining two options are automatically disabled.

- Alarm monitoring
The output is used for monitoring if an alarm has been triggered or not.
- Static level
The output is set as static, either as static on or static off.
- Pulse output
The output is set as a pulse output.

On the pulse output the meter sends out a specified number of pulses (pulse frequency) per kilowatt hour (kilovar for reactive pulse outputs). The amount of pulses sent out are in proportion to the energy flowed through the meter.

The meter has a pulse output frequency of 100 imp/kWh and the pulse width is 200 ms.

6.4 Alarm

General

The purpose of the alarm function is to enable monitoring of quantities in the meter. Monitoring can be set to high or low level detection. High level detection gives an alarm when the level of a quantity goes above the set level. Low level detection gives an alarm when the value goes below the set level.

Quantities

Depending on the meter type all or a subset of the following quantities can be monitored:

- Active power
 - Power factor
 - Current L
 - Voltage L-N
-

Functional description

When the value of the monitored quantity passes the activation level, and remains there for a period of time equal or longer than the specified time delay, the alarm is activated. In the same way, the alarm is deactivated when the value passes the deactivation level and remains there for a time equal to or longer than the specified time delay.

If the activation level is higher than the deactivation level, the alarm is activated when the value of the monitored quantity is higher than the activation level.

If the activation level is lower than the deactivation level, the alarm is activated when the value of the monitored quantity is lower than the activation level.

Chapter 7: Technical data

Overview

This chapter contains the technical specifications and the physical dimensions of the meter.

In this chapter

The following topics are covered in this chapter:

7.1 Technical Specifications	36
7.2 Physical Dimensions	38

7.1 Technical Specifications

Specifications for C11 direct connected meter

Voltage/current inputs	
Nominal voltage	230 VAC
Voltage range	230 VAC (-20% - +15%)
Power dissipation voltage circuits	< 0.8 VA (0.2 W) total
Power dissipation current circuits	0.02 W at 230 VAC and I_{ref}
Base current I_b	5 A
Reference current I_{ref}	5 A
Transitional current I_{tr}	0.5 A
Maximum current I_{max}	40 A
Minimum current I_{min}	0.25 A
Starting current I_{st}	< 20 mA
Terminal wire area	0.5 - 10 mm ²
Recommended tightening torque	0.8 Nm
General data	
Frequency	50 or 60 Hz ± 5%
Accuracy	1% (Cl.1, Cl.B)
Display of energy	6 digit LCD
Mechanical	
Material	Polycarbonate in transparent front glass and terminal cover. Glass reinforced polycarbonate in housing.
Weight	73 g
Environmental	
Operating temperature	-25°C - +85°C
Storage temperature	-25°C - +85°C
Humidity	75% yearly average, 95% on 30 days/year.
Resistance to fire and heat	Terminal block 960°C, terminal cover 650°C (IEC 60695-2-1)
Pulse output	
Current	2 - 100 mA
Voltage	5 - 40 VDC
Pulse frequency	100 imp/kWh
Pulse width	200 ms
Terminal wire area	0.5 - 6 mm ²
Recommended tightening torque	0.8 Nm
Pulse indicator (LED)	
Pulse frequency	1000 imp/kWh
Pulse length	40 ms
EMC compatibility	
Impulse voltage test	6 kV 1.2/50µs (IEC 60060-1)

Surge voltage test	4 kV 1.2/50 μ s (IEC 61000-4-5)
Fast transient burn test	4 kV (IEC 61000-4-4)
Immunity to electromagnetic HF-fields	80 MHz - 2 GHz at 10 V/m (IEC61000-4-3)
Immunity to conducted disturbance	150kHz – 80MHz, (IEC 61000-4-6)
Immunity to electromagnetic disturbances	2-150 kHz for kWh-meters
Radio frequency emission	EN 55022, class B (CISPR22)
Electrostatic discharge	15 kV (IEC 61000-4-2)
Standards	IEC 62052-11, IEC 62053-21 class 1, GB/T 17215.211-2006, GB/T 17215.321-2008 class 1 & 2, GB 4208-2008, EN 50470-1, EN 50470-3 category B

7.2 Physical Dimensions

C11 The following drawing shows the physical dimensions of the C11 meter

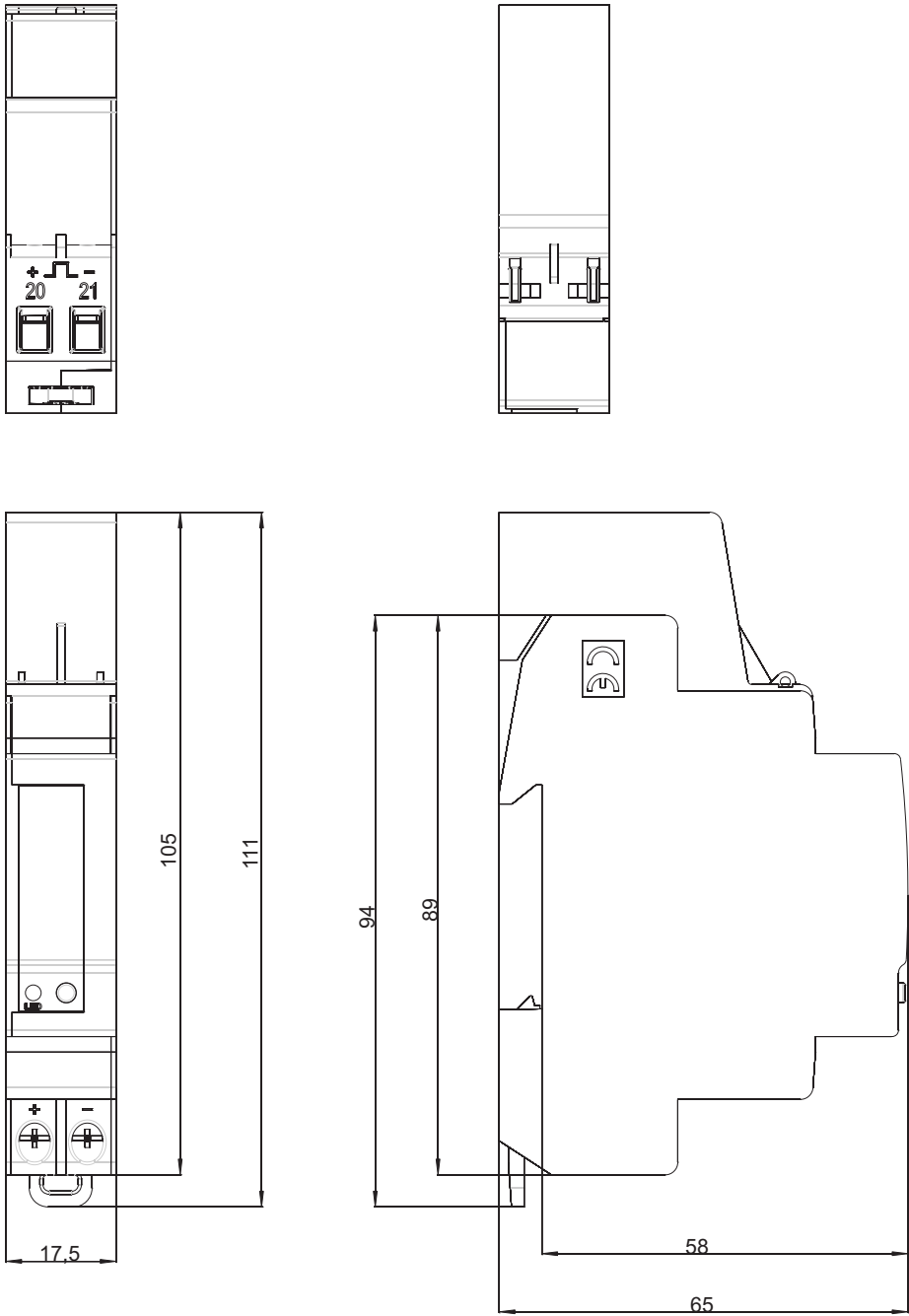

Chapter 8: Troubleshooting

Overview

This chapter describes the error codes and the warnings that can be received from the meter.

In this chapter

The following topics are covered in this chapter:

8.1 Error Codes	38
-----------------------	----

8.1 Error Codes and Warnings

Error codes

Error code	Description
Er0041	Program CRC error
Er0042	Persistent storage CRC error
Er0051	Vref is not vdd/2
Er0052	Temperature sensor error

Warnings

Warning	Description
Er1007	Negative power
Er1008	Frequency outside meter specification

Chapter 9: Service & Maintenance

Overview This chapter contains information about service and manitenance of the product.

In this chapter The following topics are covered in this chapter:

9.1 Service and Maintenance 40

9.1 Service and Maintenance

Service	This product contains no parts that can be repaired or exchanged. A broken meter must be replaced.
----------------	--

Cleaning	If the meter needs to be cleaned, use a lightly moistened cloth with a mild detergent to wipe it.
-----------------	---



Caution – Be careful that no liquid gets into the meter since it can ruin the equipment.
