



AEL.MF.11-1 - Summary Sheet

Summary

The AEL.MF.11-1 single phase meter is our best value 100 Amp check meter. This compact unit is easy to install and features a large, easy read display.

The button on the meter allows you to scroll through Date, Time, Total Energy Consumed, (kWh), as well as Maximum Demand (kW) and when this was recorded. The internal battery on the meter allows this data to be accessed even when the supply to the meter is not live, ideal for applications where the power supply may be switched off at times.

Manufactured in Europe and fully approved in accordance with the Measuring Instruments Directive (MID), this highly accurate, wall mounted meter may be used for billing and monitoring consumption on a single phase supply.

Product Code

Meter Type

Fitting Type

Max Current (Amps)

MID Approved

Smart

Input Type

Output Type

Tariffs

Import / Export

Availability

Condition

Brand

Country of

Manufacture

SPWKOM

Single Phase

Wall Mounted

100

Yes

No

Direct Connect

n/a

Single

Import Only

Next Day

New

Kohler

Turkey

Dimensions

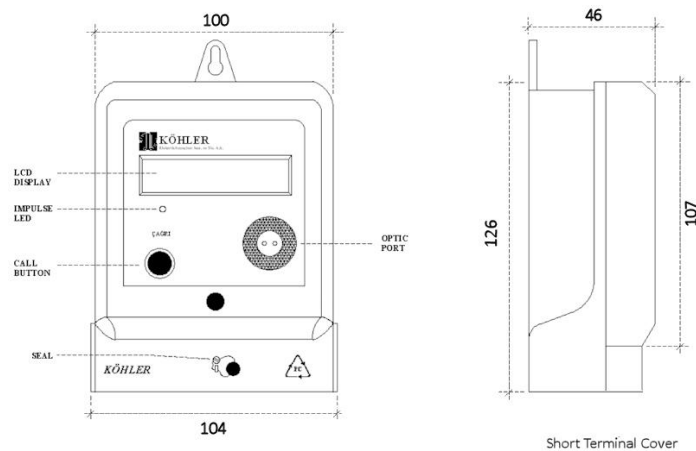

Wiring Diagram

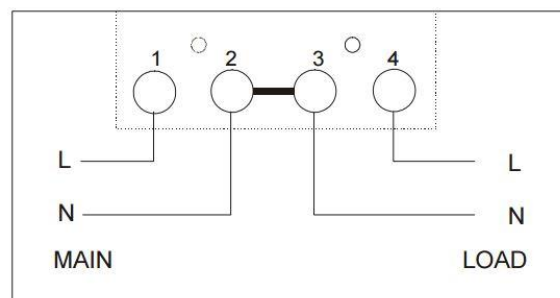

Web: www.spwales.com | Email: sales@spwales.com | Phone: 01803 295430 | Fax: 01803 212819

While Stephen P Wales Ltd has made every reasonable effort to ensure the accuracy of this information, Stephen P Wales Ltd does not guarantee that it is error-free, nor does Stephen P Wales Ltd make any other representation, warranty or guarantee that the information is accurate, correct, reliable or current. Stephen P Wales Ltd reserves the right to make any adjustments to the information contained herein at any time without notice.