

6. SETTING PROGRAMMING SWITCHES

IMPORTANT - ALWAYS DISCONNECT FROM THE MAINS BEFORE ADJUSTING.

Set time per payment as shown in Figure 12. Minutes and seconds or hours and minutes countdown is selected using the one way switch bank (see figure 11 below for position of programming switches).

Connect the antenna to the PCB using the screw terminals as shown in figures 9 and 10) and refit the front panel.

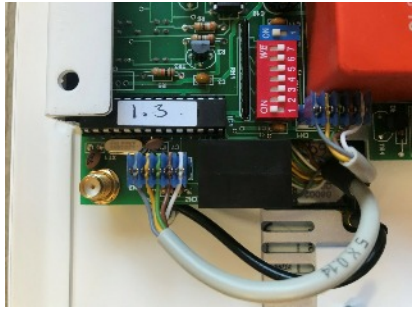

Figure 9



Figure 10

TO SET TIME PERIOD	
Switch No.	Time Period
1	1
2	2
3	4
4	8
5	16
6	32
7	64

Example set for 15 minutes

Switch numbers 1,2,3,4 ON
=1+2+4+8 = 15 minutes

Select hours or minutes

Select Time

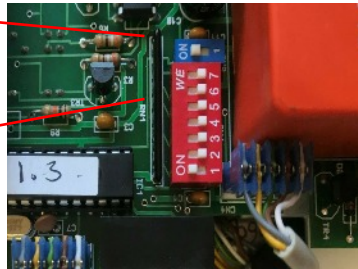

Figure 11

Standard Timer Range

Contactless Operation



INSTALLATION AND OPERATING INSTRUCTIONS FOR CONTACTLESS OPERATED TIMERS

1kVA types maximum load 4.5 Amp resistive

7kVA types maximum load 30 Amp resistive

12kVA types maximum load 50 Amp resistive

VF types for voltage free switching maximum load 5 Amp @ 230V AC



1. INTRODUCTION

All LCI meters are designed using modern electronic technology to give a very reliable unit when installed correctly. The modular construction allows for easy servicing or updating. Simple to install the meters require no maintenance other than regular emptying of the cash box. The standard output load is 1kVA but 7kVA and 12kVA options are available. The operating characteristics, as defined by BS-EN60730, are type 1B. The meters comply to the latest EMC and Low Voltage directives, meeting EN60730-1:92, EN50082-1:92, EN55014:93, and EN60555-2:87.

2. INSTALLATION

The meters are designed as independently surface mounted controls. They can be corner mounted either way unless incorporating the coin counter option when only right hand mounting is possible. Ensure ambient temperature of 40°C is not exceeded.

Before installing meter ascertain which model type and options are being installed.

- i. Lay the meter on its back
- ii. See Figure 1. Using the 2.5mm hex driver remove the flang screw and remove the front panel by pulling towards base v lifting bottom edge slightly outwards and then lifting panel **IMPORTANT**. It is essential that panel recess is clear of case lip before attempting to lift panel out. Rotate front p withdraw 9 way connector from printed circuit board, thus : front panel from the meter case. Set programming switches (s and place panel in a safe place.
- iii. Position the case on the wall and mark the top centre fixing Drill and plug the wall and fit with No. 8 or 10 screw of no 22 mm. Hang case on screw and tighten. Use a spirit level the case is perfectly level. Mark the bottom two screw positions, remove case and d plug the holes.
- iv. Remove the cable knockouts as required and fix to the wall.
- v. Using a fused double pole switch for the mains input, wire th shown in Figure 2. **IMPORTANT**. With 24V, VF (voltage-free) and 1kVA models use cable of cross sectional area not less than 1.0 mm² and fuse at 5A. With 7kVA rated models use cable of not less than 6.0 mm² and fuse as appropriate up to a maximum of 30A. For 12kVA rated models use cable of not less than 10 mm². The use of 20 mm conduit is recommended (use male thread adaptor with lock-ring e.g. Egatube type EMA/2). Alternatively fit a 20 mm nylon compression cable gland to provide strain relief.

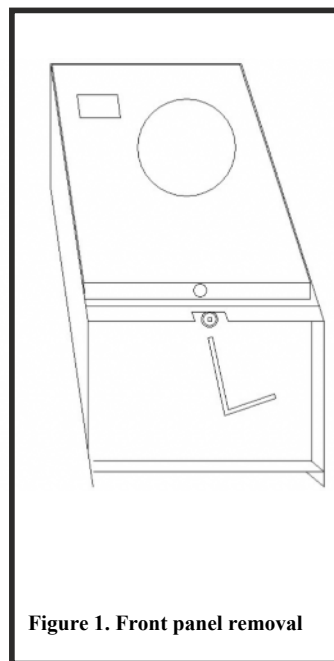

Figure 1. Front panel removal

Some models may incorporate an in line fuse. If blown, ensure new fuse is of correct value.

WARNING!

THE EARTH TERMINAL MUST BE CORRECTLY CONNECTED TO A KNOWN EARTH ENSURE EARTH WIRE IS ADEQUATELY TRAPPED BY THE TAGS OF THE CLAMPING WASHERS

- vi. Refit front panel, making sure the 9 way connector is the right way round. There is a polarising back wall to ensure correct polarity. **Forcing the connector the incorrect way round will cause irreparable damage.** Replace the flanged screw, making sure the screw head is flush with the enclosure but not over tightened.
- vii. Switch on and test for correct operation. See Section 4.

NEVER OPERATE THE UNIT WITH THE FRONT PANEL UNSECURED OR WITH THE CASE UNEARTHED.

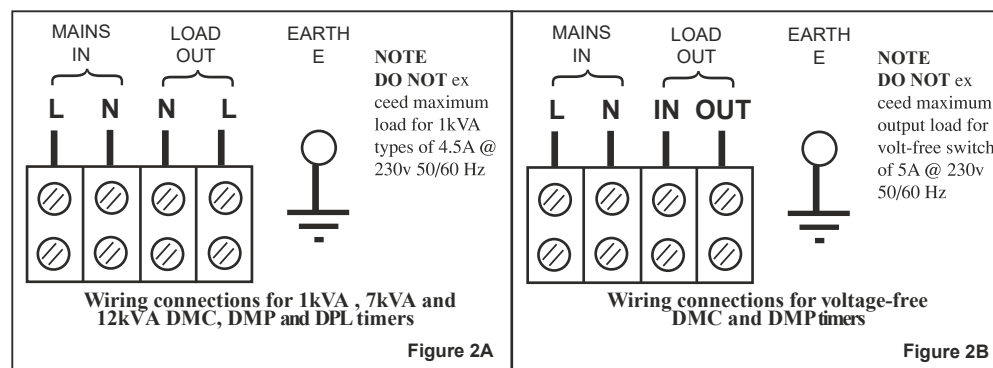

Figure 2 Input wiring connections

3. SERVICE AID

All display timers have a service aid inbuilt into the electronic software which detects a fault with the coin acceptor. If the coin acceptor jams (usually because the cashbox has not been emptied or a coin has stuck) the display will flash until the fault is cleared.

4. REPAIRS

IN MOST CASES IT IS NOT NECESSARY TO REMOVE THE METER FROM THE WALL.

In case of failure the front panel may be removed and replaced, or individual parts replaced. To replace the PCB is withdrawn, after unplugging the antenna, by sliding down the guides, being careful not to damage the contactless reader.

If the 7kVA or 12kVA relay in the back of the box fails, the loom should be pulled off, and the two M3 screws and washers removed carefully and a new relay fitted.

5. TECHNICAL SUPPORT

Answers to many technical questions may be found on the support section of Leisure Controls International's web site at www.lcigb.com/support.

Alternatively contact technical support directly by one of the following:

E-mail: support@lcigb.com
 Telephone: +44 (0) 1258 483574
 Fax: +44 (0) 1258 488526

IMPORTANT The Standard range of timers are designed for indoor use only.

Although the timing meters are strong and reliable they are targets for petty theft. We therefore recommend that cash boxes are emptied daily and left open overnight where possible.