

Rail350V - IP Installation Guide Revision 2



1 Safety

This instruction sheet gives details of safe installation and operation of the **Rail350V-IP** electricity meter. Labels on each meter give details of equipment ratings for safe operation. Take time to examine all labels before commencing installation. Safety symbols on the meter have specific meanings as:



Safety may be impaired if the instructions are not followed or the meter is used in a manner not specified by the manufacturer.



Contains no user serviceable parts. Field wiring and commissioning should only be carried out by qualified personnel, in compliance with applicable national regulations.
e.g. National Electrical Code (NEC) for US; Canadian Electrical Code for Canada

For further information contact the manufacturer:

Address: Northern Design (Electronics) Ltd: 228 Bolton Road, Bradford, West Yorkshire, BD3 0QW. (UK)
Web: <http://www.ndmeter.co.uk>
Email: sales@ndmeter.co.uk

2 Maintenance

The equipment should be maintained in good working order. Damaged equipment must be sent to the manufacturer (or his authorised agent) for repair. The meter may be cleaned by wiping lightly with a soft cloth. No solvents or cleaning agents should be used. All inputs and supplies must be isolated before cleaning any part of the equipment.

3 Intended Use

The **Rail350V-IP** is a precision multi function electricity monitor which measures system power parameters, including kW, Volts and Amps and displays them on an LCD. Measured parameters may be sent to remote systems for storage or display using an optional TCP/IP Ethernet communications interface.

The **Rail350V-IP** is intended for mounting on a standard 35mm "Top-Hat" Din Rail in a standard, secure, electrical switch enclosure so that only the front display is accessible to the end user after installation.



The safety of any system containing the meter as a component remains the responsibility of the system manufacturer. After installation in a system, the ratings of the overall system, which reflect the ratings of the meter, must be visible to the user.



*Only the front panel of the **Rail350V-IP** may remain accessible to the user after installation in a suitable switch enclosure.*



A suitably located and easily reached switch or circuit breaker must be included as part of the installation. This could, for example, be a safety-interlocking device on the door/front panel of the electrical enclosure. This switch/circuit breaker must be marked as the disconnecting device for the equipment and must comply with the relevant requirements of IEC 60947-1 and IEC 60947-3.



Disconnect / Isolate all supplies before commencing installation.

4 Standard Connections

4.1 Current Transducers



Only current transducers which meet the manufacturer's specifications should be used.



Current Transducer (CT) connections are not galvanically isolated from the voltage inputs and must therefore not be accessible to the operator after installation. Installed CT cables and any extensions to these, must not be accessible to the user.

Minimum Current Transducer Specification:

Input Current Range: 0 to 1.2 In (In = nominal rated current in amps)
Output Voltage: 0.33Vac at In
Insulation: 600Vac (Core to secondary conductors)
Cable: Operating Temperature, 105°C (221°F)
Insulated 600Vac

The following list of UL & CE recognised current transducers has been approved for use with the Cube/Rail series of meters:

Part Number	Primary Current (XXX)	Secondary	Window Size
XFR/S0142/XXX	5, 10, 30, 50, 75, 100, 150, 200Amps	0.333Vac	19.1 x 19.1mm(0.75" x 0.75")
XFR/S0152/XXX	75, 100, 150, 200, 300, 400, 600Amps	0.333Vac	31.8 x 31.8mm (1.25" x 1.25")
XFR/S0162/XXX	100, 200, 300, 600, 800, 1000, 1500Amps	0.333Vac	50.8 x 50.8mm (2.0" x 2.0")
XFR/S1142/XXX	5, 10, 30, 50, 70, 100, 150, 200Amps	0.333Vac	19.1 x 19.1mm(0.75" x 0.75")
XFR/S1152/XXX	50, 70, 100, 150, 200, 250, 300, 400, 600Amps	0.333Vac	31.8 x 31.8mm (1.25" x 1.25")
XFR/S1162/XXX	100, 200, 300, 400, 600, 800, 1000, 1200, 1500Amps	0.333Vac	50.8 x 50.8mm (2.0" x 2.0")
XFR/S1172/XXX ¹	400, 600, 800, 1000, 2000, 3000Amps	0.333Vac	127.0 x 76.2mm (5.0" x 3.0")

NOTE 1: Model XFR/S1172/XXX is only approved for use up to an ambient temperature of 30°C (86°F). All other models are approved for use up to 55°C (131°F).

If the current transducer secondary cables require extending, care must be taken to avoid pickup of electrical interference. With suitable low capacitance screened cables, the cable can be extended to 100m (328ft) or more.



*Extensions to the supplied current transducer cables must ensure all connections remain inaccessible to the operator after installation.
All cables and connections must meet the minimum specifications provided.*

4.2 Voltage Connections



To maintain proper insulation from the mains supply, the neutral wire should only be used in power networks where the system neutral is protectively earthed at some point.

4.2.1 Voltage Cables



Voltage cables must be rated for safe use in the electrical enclosure which houses the meter (e.g. UL1015) and must meet the following minimum specification: Temperature: 105°C (221°F), Insulation 600Vac.

4.2.2 Auxiliary Mains Supply

The meter is powered from an auxiliary mains supply which is required to energise the metering circuit and display. This can be connected in parallel with one of the measurement phase voltages if it is rated correctly.



Ensure the auxiliary mains supply L-N is powered from a correctly rated and fused AC source as specified on the meter label.

4.2.3 Voltage Terminals

Voltage: 277Vac (2-3, 3-4)
480Vac (4-5, 5-6)
Cable: 30-11 AWG, Stripped 6.5 to 7.0mm (0.24" to 0.28")
Torque: 0.5Nm (4.4in lb)

4.2.4 Voltage Fuses

Fuses (US/Canada)

Rated Voltage	Type	Rupture In (A)	Standards
≥ 500Vac	Fast	1.0A	UL248 (US) C22.2 No. 248 (CAN)

Fuses (Other Countries)

Rated Voltage	Type	Rupture In (A)	Standards
≥ 500Vac	Fast	1.0A	IEC 60269 - 2

4.2.5 Auxiliary Mains Fuses

Fuses (US/Canada)

Rated Voltage	Type	Rupture In (A)	Standards
≥ 250Vac	Fast	0.1A	UL248 (US) C22.2 No. 248 (CAN)

Fuses (Other Countries)

Rated Voltage	Type	Rupture In (A)	Standards
≥ 250Vac	Fast	0.1A	IEC 60269 - 2

4.3 Communications Options

The Ethernet communication port is safety isolated from the measurement voltages at a minimum of 3.5kV.



Communications cables running within an electrical enclosure may come close to high voltages and therefore must be insulated to the following minimum specification:
Safety Compliant: e.g UL1015; Operating Temperature: 105°C (221°F); Insulation 600Vac

4.3.1 Ethernet Output (Optional)

Connection: RJ45
Cable: Cat5e FTP (Foil screened)
Speed: 10/100 BaseT

For installation & settings of Ethernet, refer to the IP Meter Operating Manual Rev 1.07

4.4 Digital Outputs

Two digital outputs are available on the **Rail350V-IP** in the form of isolated volt free normally open contact pairs. The contacts are isolated from the mains input circuits (3.5kV) and at 50V between outputs (Digital Outputs 1 to 2). Digital outputs may be configured using the embedded web pages to provide Under/Over alarm status based on a selected measurement parameter and programmable limits.



Digital output cables running within an electrical enclosure may come close to high voltages and therefore must be insulated to the following minimum specification:
Safety Compliant: e.g UL1015; Operating Temperature: 105°C (221°F); Insulation 600Vac

Digital Outputs

Voltage 70Vdc/33Vac max
Current 100mA (ac/dc) max
Load 5 Watts max
Tightening < 0.25Nm
Temperature Terminals 110°C (230°F) max

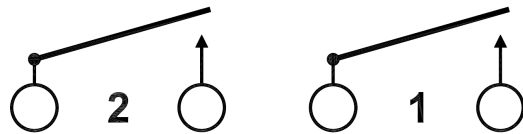

4.5 Digital Inputs

Three isolated (3.5kV) digital inputs are available on the **Rail350V-IP**. These inputs may be connected to external utility meter pulse outputs such as electricity, water, gas meters etc. Pulses detected at the digital inputs are accumulated by the **Rail350V-IP** and may be logged and profiled in the same way as energy registers monitored directly by the meter.



Risk of Equipment Damage

Only connect digital inputs to volt free contacts – DO NOT APPLY AN EXTERNAL VOLTAGE



Digital input cables running within an electrical enclosure may come close to high voltages and therefore must be insulated to the following minimum specification:

Safety Compliant: e.g UL1015; Operating Temperature: 105°C (221°F); Insulation 600Vac

Digital Inputs

Voltage 5Vdc max (internally supplied)
Current 2mA dc max (per Input)
Tightening < 0.25Nm
Temperature Terminals 110°C (230°F) max

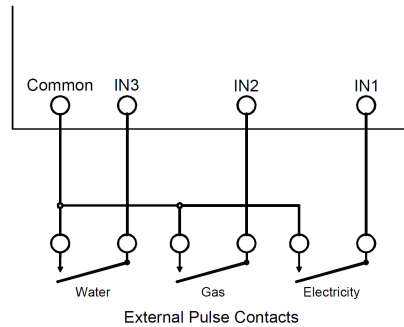

4.6 Typical Connections

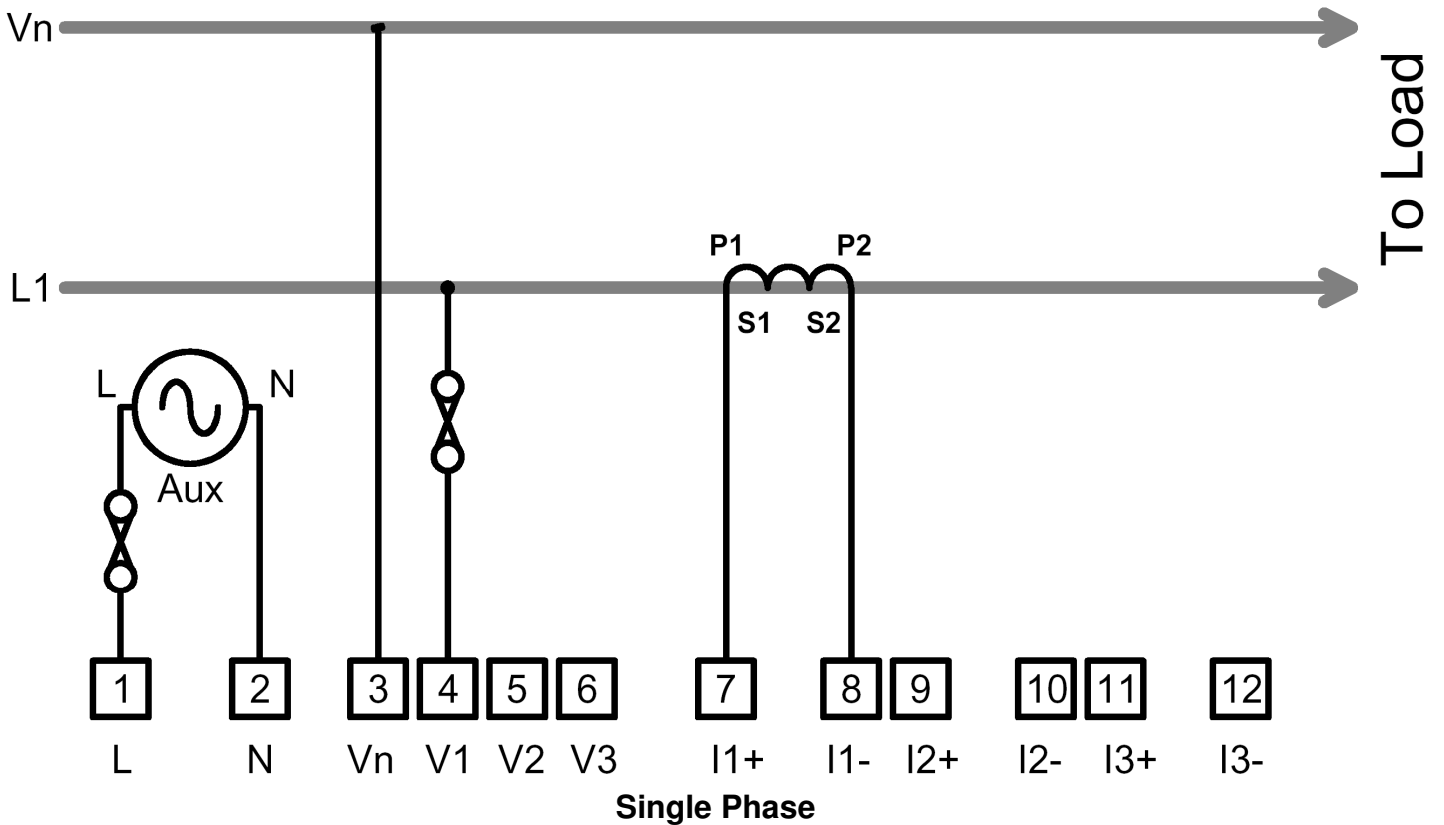
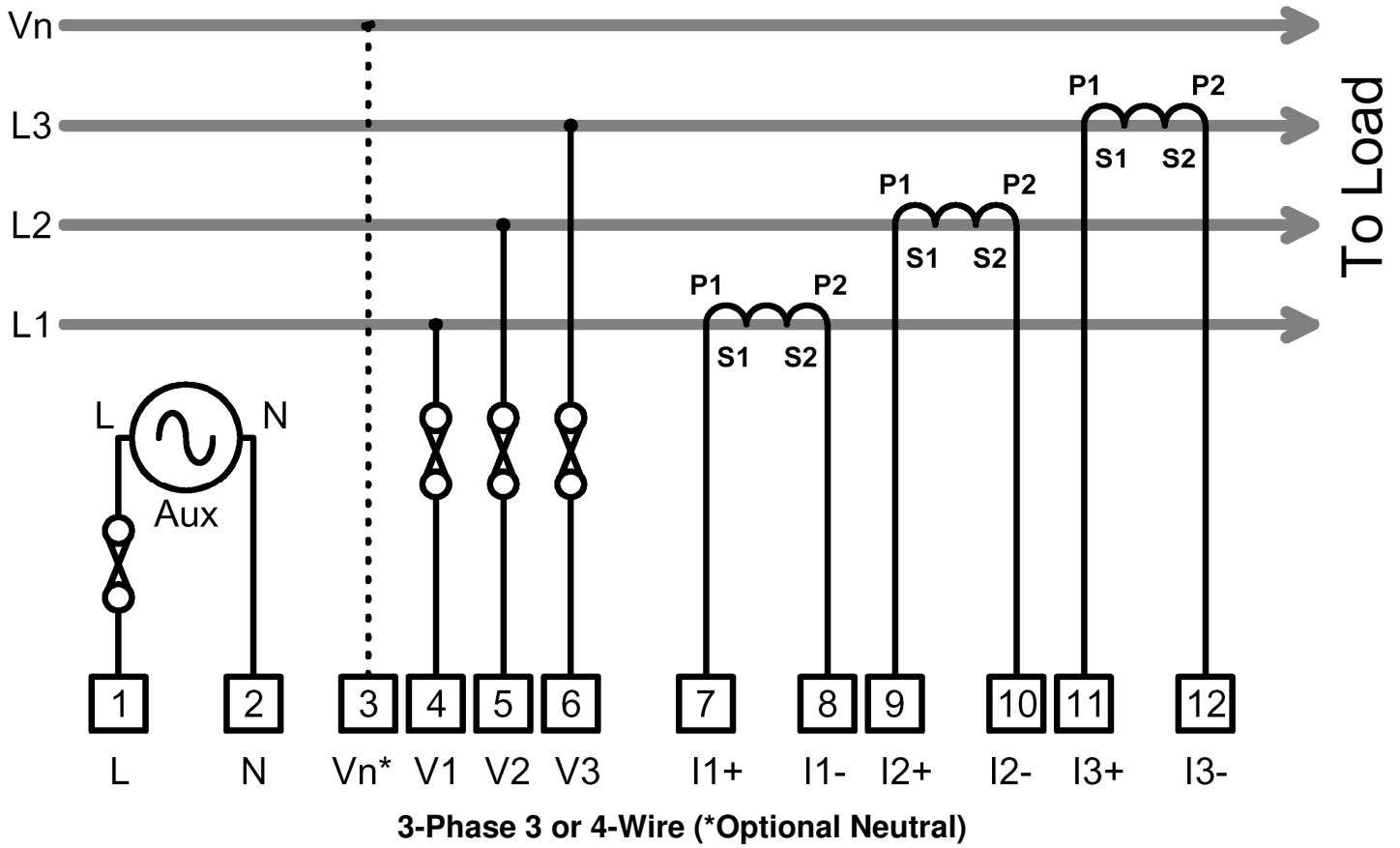

NOTE: For single phase systems it is advisable to link out unused current inputs (9-10 and 11-12) with a short insulated wire link. This prevents unwanted noise affecting meter readings.

5 Operation

5.1 Energy Displays

Press  to select kWh kvarh and Hours Run display pages.



Active Energy Register^(Note 2)





Hours Run^(Note 1)





Reactive Energy Register^(Note 2)

Note 1: The Hours Run register accumulates the total time during which the average 3-phase load current exceeds a preset level. This is always displayed with a resolution of 0.1hour. The percentage level of (I1+I2+I3) at which the Hours Run register accumulates is user programmable from 1% to 100% of full scale current and can be set through the programming menu.

Press  and  together and hold for 2 seconds to reset the hours run register. The reset of Hours run register cannot be disabled.

Note 2: Scaling of the energy registers is set by the nominal input currents and voltages and remains constant during operation of the meter. Energy registers will each accumulate from zero to 99,999,999 then restart from zero.

Press  and  together and hold for 2 seconds to reset the displayed value. This feature is disabled by default. Refer to Rail350 option links guide to enable. The reset function works simultaneously on kWh or kvarh registers.

5.2 Voltage Displays

Press  to select from the following displays;



Phase-n Voltages 1 - 3^(Note 3)



Line-Line Voltages 1 - 3^(Note 3)

5.3 Current Displays

Press  to select from the following displays;

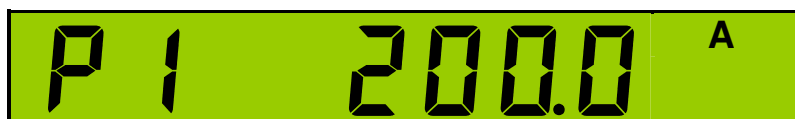

Phase 1 - 3 Current

5.4 Power Displays

Press  to select from the following displays;



System Active Power



Frequency. Hz (Phase 1 voltage)



System Power Factor (C=Capacitive)^(Note 3)



Phase 1-3 Active Power^(Note 3)





Phase 1-3 Power Factor (C=Capacitive)^(Note 3)

NOTE 3: Some display pages are removed in *Balanced Voltage Mode* (Refer to section 6.7).

6 Programming

6.1 Programming Menu

To enter programming mode:



Hold  and  together for 5 Seconds.

A **Security Code** may be required before changes to programmed parameters are allowed. This is only required if a **Security Code** greater than zero is set via serial communications. This is then stored in non-volatile memory during power interruptions.



4-Digit Security Code



To Enter A Security Code:

Press  or  to change each digit. (Lowest significant digit first).

Press  to select next most significant digit.

When a valid code is input the programming menu is displayed.

To change a Programmable Value:

Press  or  until the required value is set.

To Move to The Next Setting:

Press  until the next page in the list is displayed. Parameters are set in the following order:

Program Menu Pages



Current Sensor Primary



Nominal Line-Line V (or PT Primary)^(Note 4)



Output Pulse Rate



Pulse On Time



Pulse Output Test



Hours Run Trip Point (Percent Amps)



Voltage Input Mode



CT Auto Rotation Mode



Changes Are Stored to Non-Volatile Memory

After the last parameter is set the new values are stored and the meter continues to measure with the new settings.

6.2 Current Sensor Type Selection (CT)

Current sensor types are selected from a table of preferred types identified by their nominal primary current rating. The following types may be selected.

5, 50, 100, 150, 400, 800.

Note: Current sensors **MUST** be from the *PowerRail350V* range of input devices supplied by the manufacturer. Use of other sensors may affect accuracy & safety

6.3 Nominal Line-Line Voltage Selection (Un)

The nominal line-line voltage of the measured supply system may be programmed.

For systems without potential transformers (PTs) this should be the same as the nominal input of the meter as specified on the rating label (e.g. 480V).

For systems with PTs fitted this should match the nominal primary rating of the PT. The preferred values are:

11, 40, 48, 100, 110, 208, 400, 480, 600, 800, 1000, 1100, 2200,
3300, 4000, 4400, 6600, 7500, 10000, 11000, 15000, 22000, 33000, 66000

Note 4: If external VT is not used, **DO NOT ALTER** the voltage transformer primary setting for any other system voltage i.e. for 110V, 208V, 230V system. **LEAVE Un (Voltage Transformer Primary Setting) TO 480V ONLY.**



If external VT is used, alter the voltage transformer primary setting as stated in the following examples.

For 11000/110V VT, alter the setting to 48000 (multiplying factor: 11000 / 110 = 100 i.e. 480X100)

For 6600/110V VT, alter the setting to 28800 (multiplying factor: 6600 / 110 = 60 i.e. 480X60)

6.3.1 Fine Adjust

Fine Adjust Mode allows values other than those provided by the default tables to be set. To enter/exit **Fine Adjust Mode**:

Hold  and  together for 2 Seconds while setting **Un**. **Fine Adjust Mode** is indicated by a decimal point after "Un".

6.4 Pulse Rate Selection Table (Counts)

Pulse values are displayed scaled as 1 count of energy.

1, 2, 5, 10, 100, 1000



6.5 Pulse On-Time Selection Table

100ms ,200ms, 500ms, 1s, 2s, 3s, 5s, 10s, 20s

6.6 Pulse Output Test

This feature allows the pulse output hardware and external system connections to be commissioned without a measured load. The LCD shows **Pto** (off) and **Ptr** (run) and the number of test pulses. The test pulse rate is set automatically dependant on the programmed pulse length (maximum 0.5Hz).

Press  to start/stop the test pulses on both outputs.

Press  and  together to stop the test pulses and simultaneously reset the test counter.

6.7 Voltage Input Mode Selection

In “**Balance Voltage Mode**” the **PowerRail350** may be connected to a single voltage source in place of the three phases normally required for full accuracy measurement.

When **Balanced Voltage Mode** is enabled the voltage measured on phase 1 is copied to phases 2 & 3 and all three power-factors are assumed to be unity (1.00). In this mode, the voltage connected to phase 1 on the meter may be fed from any of the 3-Phase system voltages.

This connection is valid for loads with a near unity power-factor (PF=0.95 equates to an error of 5%) and balanced 3-Phase voltages.

The combination of **Split Core Current Sensors** and **Balanced Voltage Mode** allows for rapid commissioning where access cannot be made to 3-Phase terminations. At a later date when access is possible, for example during planned maintenance, the meter may be connected safely to the 3-Phase voltages and **Balanced Voltage Mode** de-selected.

Press  or  to toggle between **Balanced Voltage Mode** and **True 3-Phase Measurement Mode**.



True 3-Phase Measurement Mode



Balanced Voltage Mode

In **Balance Voltage Mode** some display menu pages are removed as they have little or no meaning and voltage is displayed as:



Voltage Display in Balanced Voltage Mode

Single Phase kW, Power Factor and kvarh displays are removed while **Balanced Voltage Mode** is enabled.



6.8 CT Auto Rotation Mode

When “**CT Auto Rotation Mode**” is selected, the orientation of each **Current Transformer (CT)** on its respective cable becomes irrelevant. It is therefore possible to pass the cable through the centre of the CT in either direction. In this mode current direction is ignored and all power is assumed to be feeding a load (import).

When “**CT Auto Rotation Mode**” is de-selected (“**True Rotation Mode**”) current direction is monitored and measurement of import and export power is provided.

In both modes it is essential to place each CT on the correct phase conductor associated with the relevant phase voltage: Therefore link **CT1 with V1**, **CT2 with V2**, **CT3 with V3**.

PowerRail350 meters are normally supplied with “**CT Auto Rotation Mode**” selected. In order to detect Positive and Negative power values in all four quadrants it is necessary to de-select “**CT Auto Rotation Mode**”.

In the programming Menu Press  or  to toggle between **CT Auto Rotation Mode** and **True Rotation Mode**.



CT Auto Rotation Mode



True Rotation Mode

NOTE: **CT Auto Rotation Mode** is not available when **Balanced Voltage Mode** is selected as all Power Factors are assumed to be unity and current phase and direction is ignored.

7 Specification

INPUTS	
System	3 Phase 3 or 4 Wire Unbalanced Load or Single Phase
Voltage Un	480/277V. 3 Phase 3 or 4 Wire
Current Sensors	
Output @ Nominal In	0.333Vac
Accuracy	±1% (0.1In – 1.2In)
Phase Error	5A-50A Models <2.5° at 0.5In. Other models <2.0° at 0.5In
Measurement Range	Voltage 20% to 120% Un (Max 520V L-L, 300VL-n) Current 0.2% to 120%
Frequency Range	Fundamental 45 to 65Hz Harmonics Up to 30th harmonic at 50Hz Individual to the 15 th
Voltage Burden	<0.1VA per phase
Overload	Voltage x4 for 1 hour Current x 2 Continuous
DISPLAY	
Type	Custom, Supertwist, LCD
Data Retention	10 years min. Stores kWh & Meter set-up
Format	8 x 6.66mm (0.31" x 0.26") high digits with DPs & 3.2mm (0.13") legends
Scaling	Direct reading. User programmable CT & VT CT Primary programmable from 5A to 25kA VT primary programmable from 11V to 440kV
Legends	Wh, kWh, MWh etc. depending on user settings
AUXILIARY SUPPLY	
Standard	100-240Vac 45-65 Hz
Load	5 Watt Max.
METER ACCURACY All errors ± 1 digit	
kWh	Better than Class 1 per EN 62053-21 & BS 8431
Kvarh	Better than Class 2 per EN 62053-23 & BS 8431
kW & kVA	Better than Class 0.25 IEC 60688
kvar	Better than Class 0.5 IEC 60688
Amps & Volts	Class 0.1 IEC 60688 (0.01In – 1.2In or 0.1Un – 1.2Un)
PF	±0.2° (0.05In – 1.2In and 0.2Un – 1.2Un)
Neutral Current	Class 0.5 IEC 60688 (0.05In – 1.2In)
OVERALL METERING ACCURACY	
5A-50A Models	Better than Class 2 Meter with Class 1 CTs
Other Models	Better than Class 1 Meter with Class 1 CTs

Digital Outputs	
Function	Programmable alarm status
Pulse Period	0.1 sec. default; Settable between 0.1 and 20 sec
Rise & Fall Time	< 2.0ms
Type	N/O Volt free contact. Optically isolated BiFET
Contacts	100mA ac/dc max ; 70Vdc/33Vac max ; 5W maximum load
Isolation	3.5kV 50Hz 1 minute
Digital Inputs	
Function	Counter Inputs from external volt-free contacts
Pulse Period	50mS minimum
Wetting Voltage	5.0V dc maximum (Internally supplied)
Wetting Current	2mA dc maximum (Internally supplied)
Isolation	3.5kV 50Hz 1 minute
ETHERNET (Option)	
Electrical	IEEE std 802.3. 2000 Edition
Data Rate	10 Mbits/s
Protocol	TCP, UDP, DHCP, FTP, TFTP, HTTP, SNTP, SNMP, Modbus TCP
Connection	10/100 Base T - RJ45
Isolation	3.5kV
GENERAL	
Temperature	Operating -10°C to +55°C (14°F to 131°F) Storage -25°C to +70°C (-13°F to 158°F)
Humidity	< 75% non-condensing
Environment	IP20 (when correctly mounted, as described, in a panel) Altitude <2000m (6561ft)
MECHANICAL	
Enclosure	DIN 43880, 6-Modules Wide
Material	Noryl® with fire protection to UL94-V-O. Self extinguishing
Dimensions	106 x 90 x 58mm (Cut out 106 x 45mm) 4.17" x 3.54" x 2.28" (Cut out 4.17" x 1.77")
Weight	~ 150 gms
SAFETY	
Conforms to	EN 61010-1 Overvoltage Category III & BS 8431

E. & O. E.

© Northern Design (Electronics) Ltd, October 2016