



Iskra MT174 – Billing Meter - Summary Sheet

Summary

The Iskra MT174-D2 is quite simply the best wall mounted, direct connect, 3 phase meter on the market with regards to functionality and affordability. The meter is MID approved for billing applications and is manufactured in Europe, (Slovenia).

We have set this model up for use as a billing meter, and so it will record monthly usage on the 1st of each month at 0:00 over a period of 9 months. Perfect for those looking to bill consumers on a regular basis, but don't have the time or resources to manually read the meter on a set date monthly. The default display will show total Energy (kWh) consumed, whereas the manual scroll will show each months usage, as well as the current date and time for reference.

An alternate date and time that a reading is recorded, as well as a number of other parameters and multiple tariffs, can be pre-programmed on to the meter as an optional extra.

This meter has a single pulse output and an RS485 connection. It is suitable for use in three phase 3-and 4-wire networks as well as single phase 2-wire networks.

Product Code

TPWISB

Meter Type

Three Phase

Fitting Type

Wall Mount

Max Current (Amps)

120

MID Approved

Yes

Smart

No

Input Type

Direct Connect

Output Type

RS485 & Pulse

Tariffs

Single

Import / Export

Import Only

Availability

Next Day

Condition

New

Brand

Iskra

Country of Manufacture

Slovenia

Measured Parameters

Active Energy (kWh)	✓	Line Power Factor (PF)	✗
Active Power (W) *	✓	Line Reactive Power (kVAr) *	✓
Apparent Energy (kVAh) *	✓	Line to Line Voltage (V)	✗
Apparent Power (VA) *	✓	Line to Neutral Voltage (V) *	✓
Average Current (I)	✗	Maximum Current (I) *	✓
Average Power Demands (W)	✗	Maximum Power Demands (W) *	✓
Average Voltage (V)	✗	Maximum Voltage (V) *	✓
Current (I) *	✓	Power Factor (PF) *	✓
Current in Neutral (I)	✗	Reactive Energy (kVArh) *	✓
Frequency (Hz) *	✓	Reactive Power (VAr) *	✓
Hours Run (hr)	✗	Total Harmonic Distortion (Amps)	✗
Line Active Power (W) *	✓	Total Harmonic Distortion (Volts)	✗
Line Apparent Power (kVA)	✗	Voltage (V) *	✓
Line Current (I) *	✓		

* These parameters can be pre-programmed on to the meter as an optional extra.

Dimensions

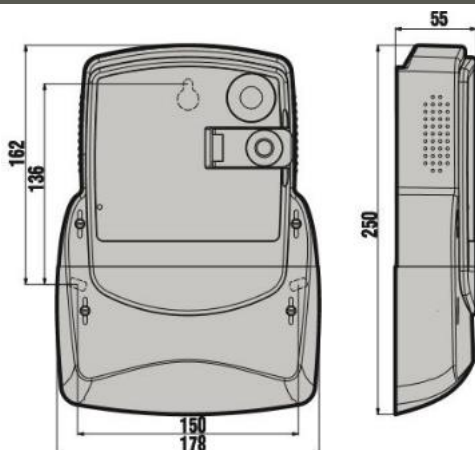

Wiring Diagram

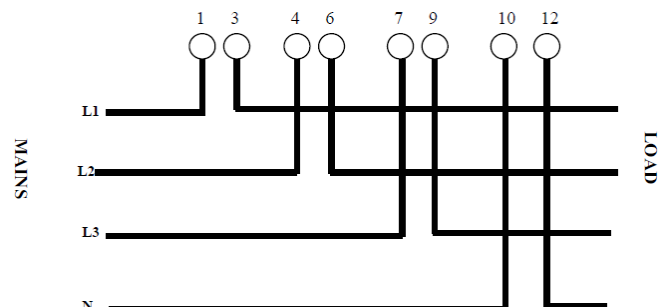

Web: www.spwales.com | Email: sales@spwales.com | Phone: 01803 295430 | Fax: 01803 212819

While Stephen P Wales Ltd has made every reasonable effort to ensure the accuracy of this information, Stephen P Wales Ltd does not guarantee that it is error-free, nor does Stephen P Wales Ltd make any other representation, warranty or guarantee that the information is accurate, correct, reliable or current. Stephen P Wales Ltd reserves the right to make any adjustments to the information contained herein at any time without notice.